

# VEHICLES

Experiments in Synthetic Psychology

Valentino Braitenberg

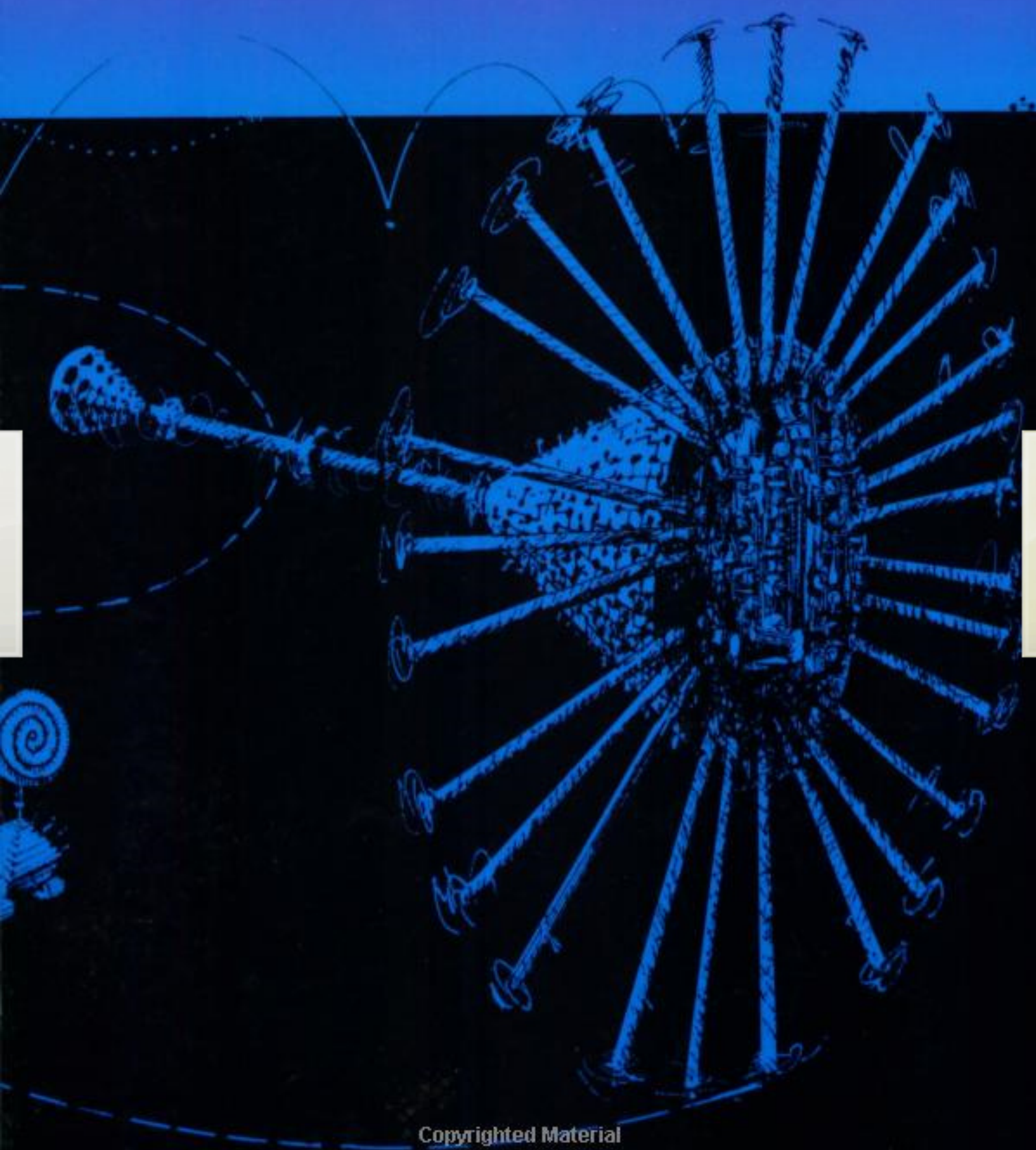

## Introduction

# *Let the Problem of the Mind Dissolve in Your Mind*

This is an exercise in fictional science, or science fiction, if you like that better. Not for amusement: science fiction in the service of science. Or just science, if you agree that fiction is part of it, always was, and always will be as long as our brains are only minuscule fragments of the universe, much too small to hold all the facts of the world but not too idle to speculate about them.

I have been dealing for many years with certain structures within animal brains that seemed to be interpretable as pieces of computing machinery because of their simplicity and/or regularity. Much of this work is only interesting if you are yourself involved in it. At times, though, in the back of my mind, while I was counting fibers in the visual ganglia of the fly or synapses in the cerebral cortex of the mouse, I felt knots untie, distinctions dissolve, difficulties disappear, difficulties I had experienced much earlier when I still held my first naive philosophical approach to the problem of the mind. This process of purification has been, over the years, a delightful experience. The text I want you to read is designed to convey some of this

to you, if you are prepared to follow me not through a world of real brains but through a toy world that we will create together.

We will talk only about machines with very simple internal structures, too simple in fact to be interesting from the point of view of mechanical or electrical engineering. Interest arises, rather, when we look at these machines or vehicles as if they were animals in a natural environment. We will be tempted, then, to use psychological language in describing their behavior. And yet we know very well that there is nothing in these vehicles that we have not put in ourselves. This will be an interesting educational game.

Our vehicles may move in water by jet propulsion. Or you may prefer to imagine them moving somewhere between galaxies, with negligible gravitational pull. Remember, however, that their jets must expel matter in order to function at all, and this implies replenishment of the food stores within the vehicles, which might be a problem between galaxies. This suggests vehicles moving on the surface of the earth through an agricultural landscape where they have good support and can easily find the food or fuel they need. (Indeed the first few chapters here conjure up images of vehicles swimming around in the water, while later what comes to mind are little carts moving on hard surfaces. This is no accident, if the evolution of vehicles 1 to 14 in any way reflects the evolution of animal species.)

It does not matter. Get used to a way of thinking in which the hardware of the realization of an idea is much less important than the idea itself. Norbert Wiener was emphatic about this when he formulated the title of his famous book: *Cybernetics, or Control and Communication in Animals and Machines*.

## Vehicle 1

### *Getting Around*

Vehicle 1 is equipped with one sensor and one motor (figure 1). The connection is a very simple one. The more there is of the quality to which the sensor is tuned, the faster the motor goes. Let the quality be temperature and let the force exerted by the motor be exactly proportionate to the absolute temperature (the temperature above zero degrees Kelvin) measured by the sensor. The vehicle will move, wherever it is (the absolute temperature is nowhere equal to zero), in the direction in which it happens to be pointing. It will slow down in cold regions and speed up where it is warm.

Here we have introduced a bit of Aristotelian physics. Aristotle, like everybody else between this ancient Greek philosopher and the less ancient Italian physicist Galileo, thought that the speed of a moving body is proportionate to the force that drives it. This is true in most instances, namely when there is friction to slow down the vehicle. Normally friction will see to it that the velocity becomes zero in the absence of any force, that it will stay at a certain small value for a certain small force, at a higher value for a higher force, and so forth.

Of course, as you all know, this is not true for heavenly bodies

(especially if you don't invest astronomical time in observing them). Their velocity is a complicated result of all the forces that ever hit them. This is another reason for letting our vehicles move in water or on the surface of the earth rather than in outer space.

In this Aristotelian world our vehicle number 1 may even come to rest. This will happen when it enters a cold region where the force exerted by its motor, being proportionate to the temperature, becomes smaller than the frictional force.

Once you let friction come into the picture, other amazing things may happen. In outer space Vehicle 1 would move on a straight course with varying speed (the gravitational pull of neighboring galaxies averages out to nothing). Not so on earth. The friction, which is nothing but the sum of all the microscopic forces that arise in a situation too messy to be analyzed in detail, may not be quite symmetrical. As the vehicle pushes forward against frictional forces, it will deviate from its course. In the long run it will be seen to move in a complicated trajectory, curving one way or the other without apparent good reason. If it is very small, its motion will be quite erratic, similar to "Brownian motion," only with a certain drive added.

Imagine, now, what you would think if you saw such a vehicle swimming around in a pond. It is restless, you would say, and does not like warm water. But it is quite stupid, since it is not able to turn back to the nice cold spot it overshot in its restlessness. Anyway, you would say, it is ALIVE, since you have never seen a particle of dead matter move around quite like that.

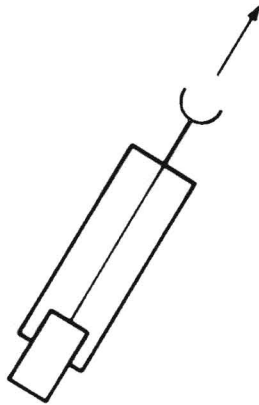

**Figure 1**  
Vehicle 1, the simplest vehicle. The speed of the motor (rectangular box at the tail end) is controlled by a sensor (half circle on a stalk, at the front end). Motion is always forward, in the direction of the arrow, except for perturbations.

## Vehicle 2

### *Fear and Aggression*

Vehicle 2 is generally similar to Vehicle 1 except that it has two sensors, one on each side, and two motors, right and left (figure 2). You may think of it as being a descendant of Vehicle 1 through some incomplete process of biological reduplication: two of the earlier brand stuck together side by side. Again, the more the sensors are excited, the faster the motors run.

Of course you notice right away that we can make three kinds of such vehicles, depending on whether we connect (a) each sensor to the motor on the same side, (b) each sensor to the motor on the opposite side, or (c) both sensors to both motors. We can immediately dismiss case (c), for this is nothing but a somewhat more luxurious version of Vehicle 1. The difference between (a) and (b), however, is very interesting.

Consider (a) first. This vehicle will spend more time in the places where there is less of the stuff that excites its sensors and will speed up when it is exposed to higher concentrations. If the source of the stuff (say, light in the case of light sensors) is directly ahead, the vehicle may hit the source unless it is deflected from its course. If the source is to one side (figure 3), one of the sensors, the one nearer to the source, is excited more than the other. The corresponding

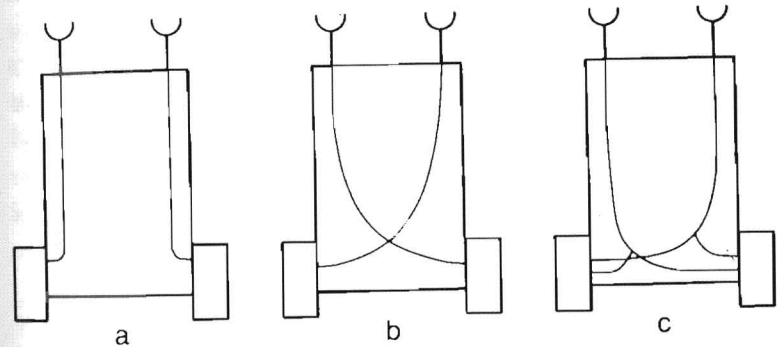

**Figure 2**  
Vehicle 2, with two motors and two sensors; otherwise like Vehicle 1. The connections differ in a, b, and c.

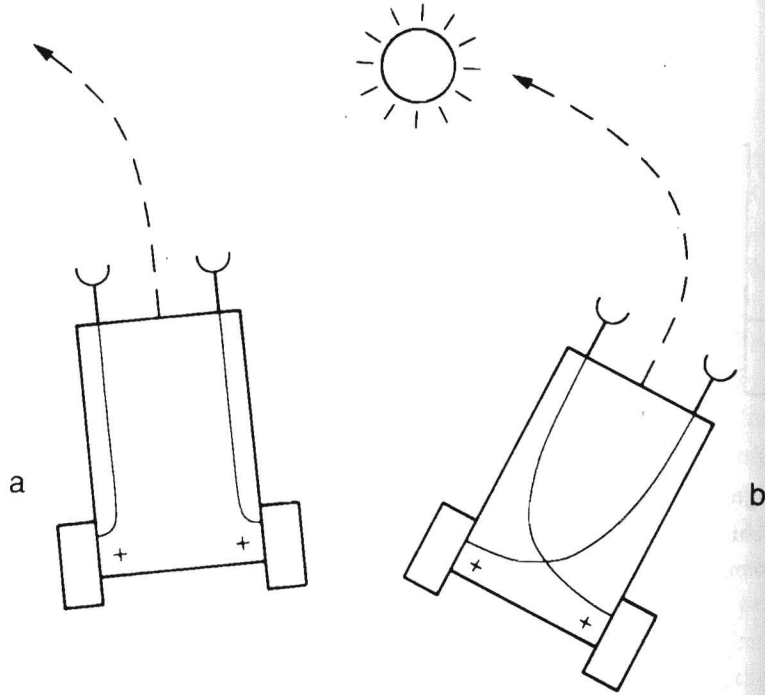

**Figure 3**  
Vehicles 2a and 2b in the vicinity of a source (circle with rays emanating from it). Vehicle 2b orients toward the source, 2a away from it.

motor will work harder. And as a consequence the vehicle will turn away from the source.

Now let us try the other scheme of sensory-motor connections, (b) in figure 3. No change if the source is straight ahead. If it is to one side, however, we notice a difference with respect to Vehicle 2a. Vehicle 2b will turn toward the source and eventually hit it. There is no escaping: as long as 2b stays in the vicinity of the source, no matter how it stumbles and hesitates, it will hit the source frontally in the end. Only in the unlikely case that a strong perturbation in its course makes it turn exactly away from the source, and no further perturbation occurs, can it escape its fate.

Let Vehicles 2a and 2b move around in their world for a while and watch them. Their characters are quite opposite. Both DISLIKE sources. But 2a becomes restless in their vicinity and tends to avoid them, escaping until it safely reaches a place where the influence of the source is scarcely felt. Vehicle 2a is a COWARD, you would say. Not so Vehicle 2b. It, too, is excited by the presence of sources, but resolutely turns toward them and hits them with high velocity, as if it wanted to destroy them. Vehicle 2b is AGGRESSIVE, obviously.

### Vehicle 3

### *Love*

The violence of Vehicle 2b, no less than the cowardice of its companion 2a, are traits that call for improvement. There is something very crude about a vehicle that can only be excited by the things it smells (or sees or feels or hears) and knows no soothing or relaxing stimuli. What comes to mind is to introduce some inhibition in the connections between the sensors and the motors, switching the sign of the influence from positive to negative. This will let the motor slow down when the corresponding sensor is activated. Again we can make two variants, one with straight and one with crossed connections (figure 4). Both will slow down in the presence of a strong stimulus and race where the stimulus is weak. They will therefore spend more time in the vicinity of the source than away from it. They will actually come to rest in the immediate vicinity of the source.

But here we notice a difference between the vehicle with straight connections and the one with crossed connections. Approaching the source, the first (figure 4a) will orient toward it, since on an oblique course the sensor nearer to the source will slow down the motor on the same side, producing a turn toward that side. The vehicle with straight connections will come to rest facing the

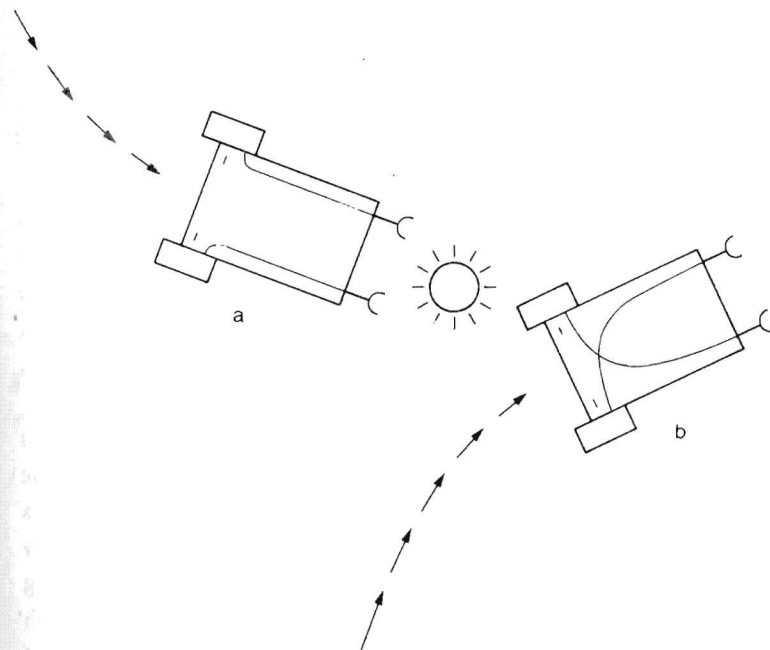

Figure 4  
Vehicle 3, with inhibitory influence of the sensors on the motors.

source. The vehicle with crossed connections (figure 4b) for analogous reasons will come to rest facing away from the source and may not stay there very long, since a slight perturbation could cause it to drift away from the source. This would lessen the source's inhibitory influence, causing the vehicle to speed up more and more as it gets away.

You will have no difficulty giving names to this sort of behavior. These vehicles LIKE the source, you will say, but in different ways. Vehicle 3a LOVES it in a permanent way, staying close by in quiet admiration from the time it spots the source to all future time. Vehicle 3b, on the other hand, is an EXPLORER. It likes the nearby source all right, but keeps an eye open for other, perhaps stronger sources, which it will sail to, given a chance, in order to find a more permanent and gratifying appeasement.

But this is not yet the full development of Vehicle 3. We are now ready to make a more complete model using all the behavioral traits at our disposal. Call it Vehicle 3c. We give it not just one pair of sensors but four pairs, tuned to different qualities of the environment, say light, temperature, oxygen concentration, and amount of organic matter (figure 5). Now we connect the first pair to the motors with uncrossed excitatory connections, as in Vehicle 2a, the second pair with crossed excitatory connections, as in Vehicle 2b, and the third and the fourth pairs with inhibitory connections, crossed and uncrossed, as in Vehicles 3b and 3a.

This is now a vehicle with really interesting behavior. It dislikes high temperature, turns away from hot places, and at the same time seems to dislike light bulbs with even greater passion, since it turns toward them and destroys them. On the other hand it definitely seems to prefer a well-oxygenated environment and one containing many organic molecules, since it spends much of its time in such places. But it is in the habit of moving elsewhere when the supply of either organic matter or (especially) oxygen is low. You cannot help admitting that Vehicle 3c has a system of VALUES, and, come to

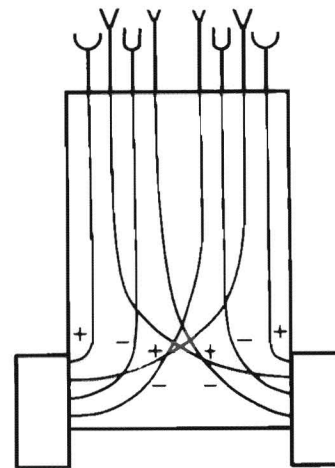

Figure 5

A multisensorial vehicle of brand 3c.



think of it, KNOWLEDGE, since some of the habits it has, like destroying light bulbs, may look quite knowledgeable, as if the vehicle knows that light bulbs tend to heat up the environment and consequently make it uncomfortable to live in. It also looks as if it knows about the possibility of making energy out of oxygen and organic matter because it prefers places where these two commodities are available.

But, you will say, this is ridiculous: knowledge implies a flow of information from the environment into a living being or at least into something like a living being. There was no such transmission of information here. We were just playing with sensors, motors, and connections: the properties that happened to emerge may look like knowledge but really are not. We should be careful with such words.

You are right. We will explain in a later chapter (on Vehicle 6) how knowledge may enter a system of connections. And we will introduce an alternative way of incorporating knowledge into the system in our chapter on Vehicle 7. In any case, once knowledge is incorporated, the resulting vehicle may look and behave quite like our Vehicle 3c.

Meanwhile I invite you to consider the enormous wealth of different properties that we may give Vehicle 3c by choosing various sensors and various combinations of crossed and uncrossed, excitatory and inhibitory, connections.

If you consider the possibility of strong and weak influences from the sensors to the motors, you realize that the variety becomes even greater. The vehicle may not care much about light but care very much about temperature. Its sense of smell may be much keener for organic matter than it is for oxygen or vice versa. And there may be many more than just four pairs of sensors and four sensory qualities: the vehicles may be equipped with all sorts of shrewd detectors of energy and of chemicals. But this is best discussed in connection with a new idea incorporated in the vehicles of the next chapter.